

Shears and Rail Cutters

ISS and IRC Series





ISS shears

Vital tools for anyone working in the scrap metal or recycling sectors, Indeco ISS Steel Shears stand out for their cutting-edge design, for their extreme robustness and for their technical innovations which substantially increase their efficiency.

Rapid, efficient and surprisingly powerful, Indeco ISS shears are the ideal choice for demolishing any type of metal structure.

Indeco's tried and tested continuous rotation hydraulic system, found on all of our other rotating products, enables the shear to work in the best possible position while its large jaw opening, fast cycle times and its incredible cutting power make all demolition operations fast and effective. Special extra-strength HARDOX® alloy steel make ISS shears outstandingly resistant and reliable. Each of the main knives and guide-blades was designed with four cutting surfaces so they can be rotated three times before replacement thereby assuring more consistency, uptime and production in your operation.

IRC Rail Cutter

New addition to the range of Indeco products dedicated to the recycling of ferrous materials, the IRC Rail-Cutting Shears are hydraulic tools specifically designed for cutting railway tracks, tramway rails, and underground rails, made with heat-treated steel to withstand the enormous forces. The special design of their jaws, combined with the efficiency of the hydraulic system, and the sturdiness of the structure in special HARDOX® steel, lets you cut rails up to 47 lb/ft of mass per metre, with hardness up to 300 Brinell. The Indeco IRC shear is designed for optimum operation on the various railway track standards that are found in the EU, in the USA and in Asian countries.



Features of Indeco hydraulic shears

The regeneration valve [1] speeds up no-load movement of the jaw, which opens and closes more quickly, thus reducing cycle times and increasing productivity.

The chassis [2], made from extra-strength HARDOX® alloy steel, eliminates any flexing of the shear body.

The unique integrated dual guide system [3] can be used to adjust the alignment tolerance of the jaw and prevents it from buckling during the cutting stroke.

The interchangeable “quick change” wear bushings [4] ensure that the knives are always optimally aligned.

The heavy-duty pivot group [5] provides long-term cutting efficiency, keeps jaws aligned and prevents buckling.

The innovative design [6] improves cutting efficiency compared to similar products.

The large jaw opening [7] provides greater flexibility for numerous applications.

The special insert bushings [8] are made from an anti-friction material with a dust seal.

The large, powerful hydraulic cylinder [9] is an exclusive Indeco design, and provides enough force to deal with any type of working conditions. Its long-lasting seals are able to withstand up to 700 bar of pressure.

The baseplate for the ISS in fixed configuration [10] makes the attachment much lighter and less bulky, which means that a larger shear can be used on the excavator.

The shears have full high-speed 360° hydraulic rotation [11] for better positioning and optimal cutting in any working position.

The mounting bracket for the 2nd-member configuration [12] is used to mount the ISS straight onto the excavator boom. In this configuration, ideal for recycling ferrous material, a large attachment can be mounted even on a relatively light carrier.

The universal baseplate for 2nd member mounting brackets [13] is compatible with all carriers.

The 3rd member mounting bracket [14] is used to mount the ISS on the carrier stick (bucket-mounted), ideal for demolition jobs.

The attachment plate [15] is compatible with the plate for Indeco hammers of similar weight.

In the latest design [16], the shear is more compact with a thicker casing, thus improving its manoeuvrability and balance, as well as increasing its overall robustness.

2nd and 3rd member configuration

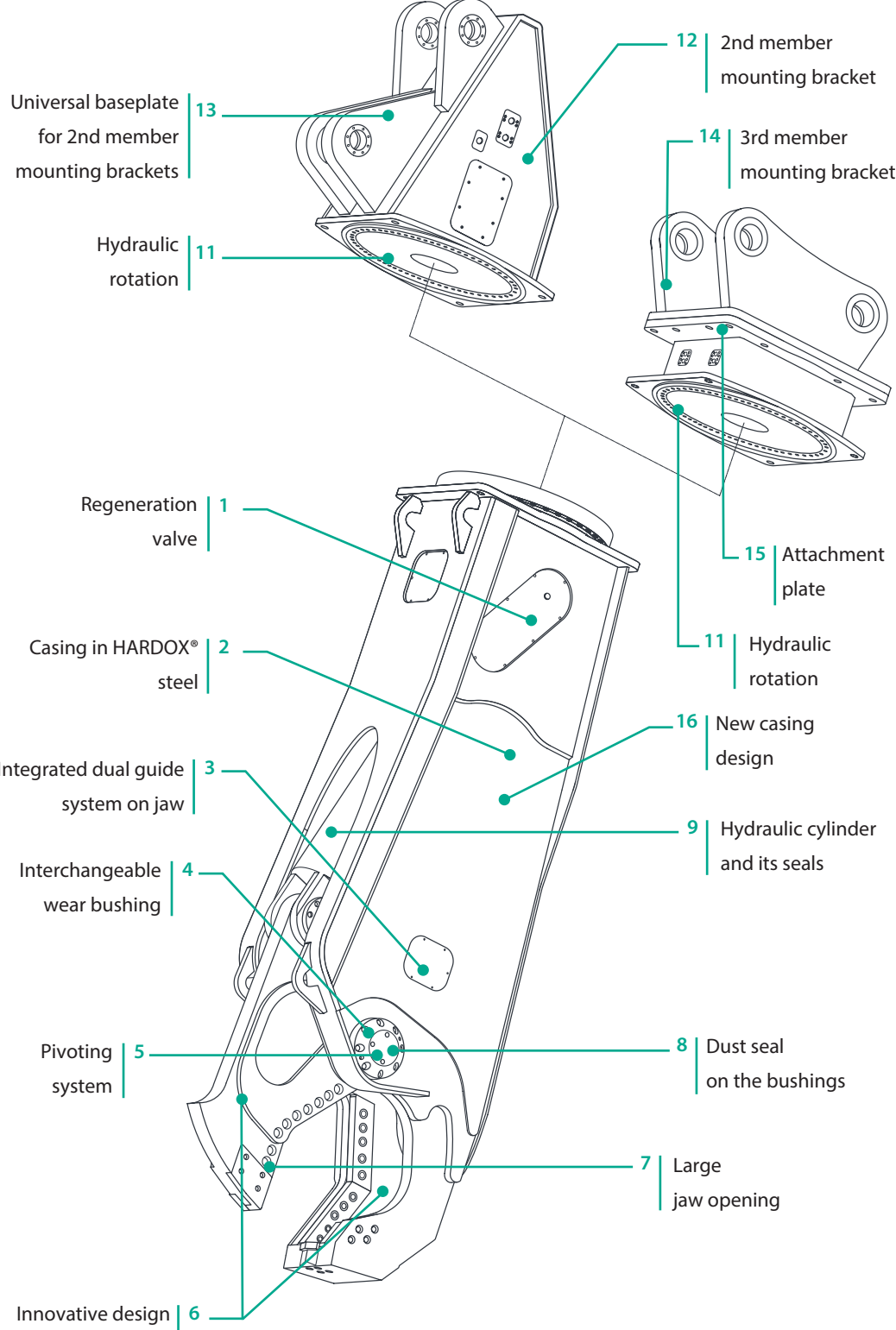

Fixed configuration

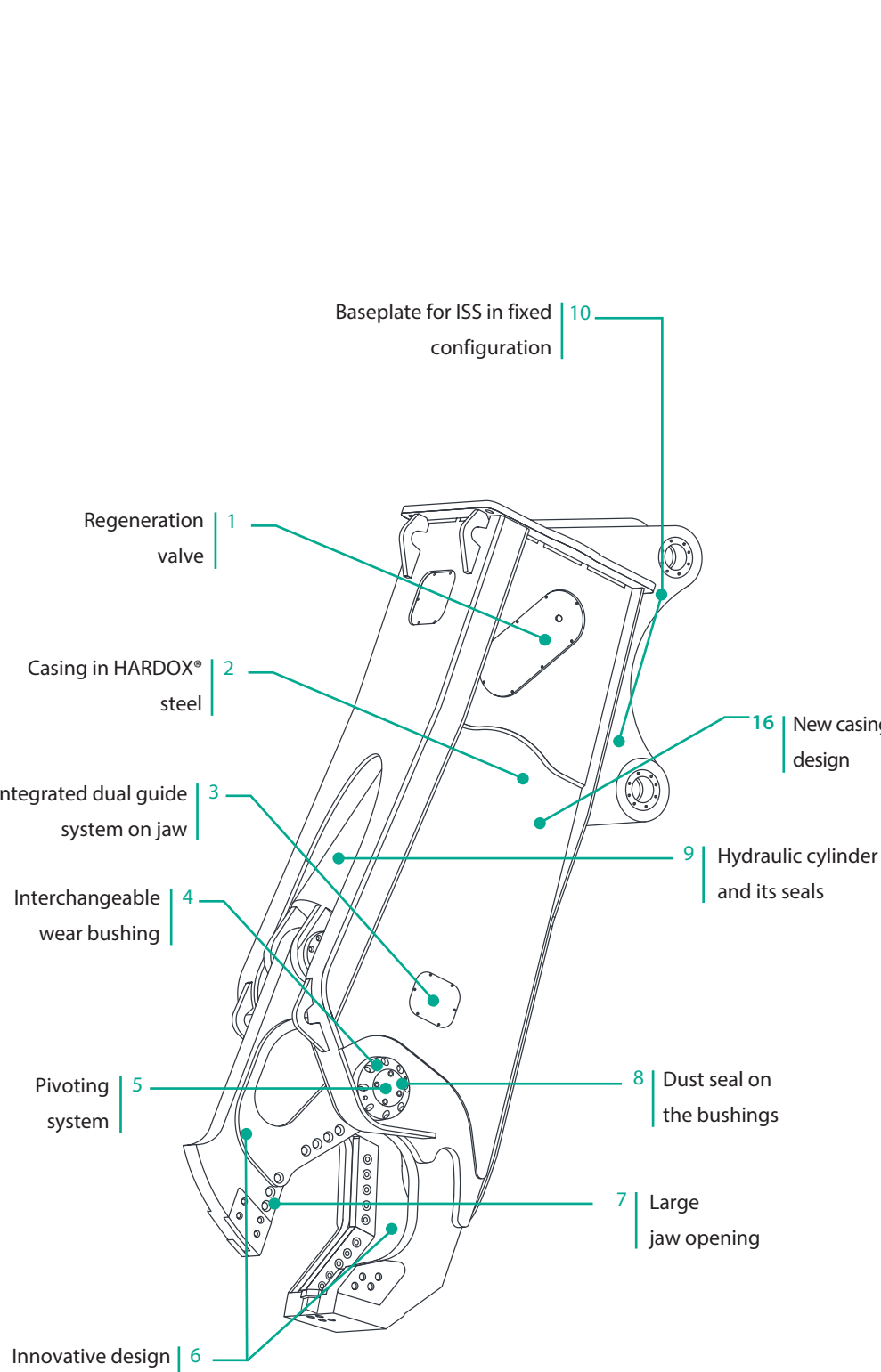



Cutting capacity

The Indeco ISS shears have exceptional capacity and cutting force, due to the following specific design features:

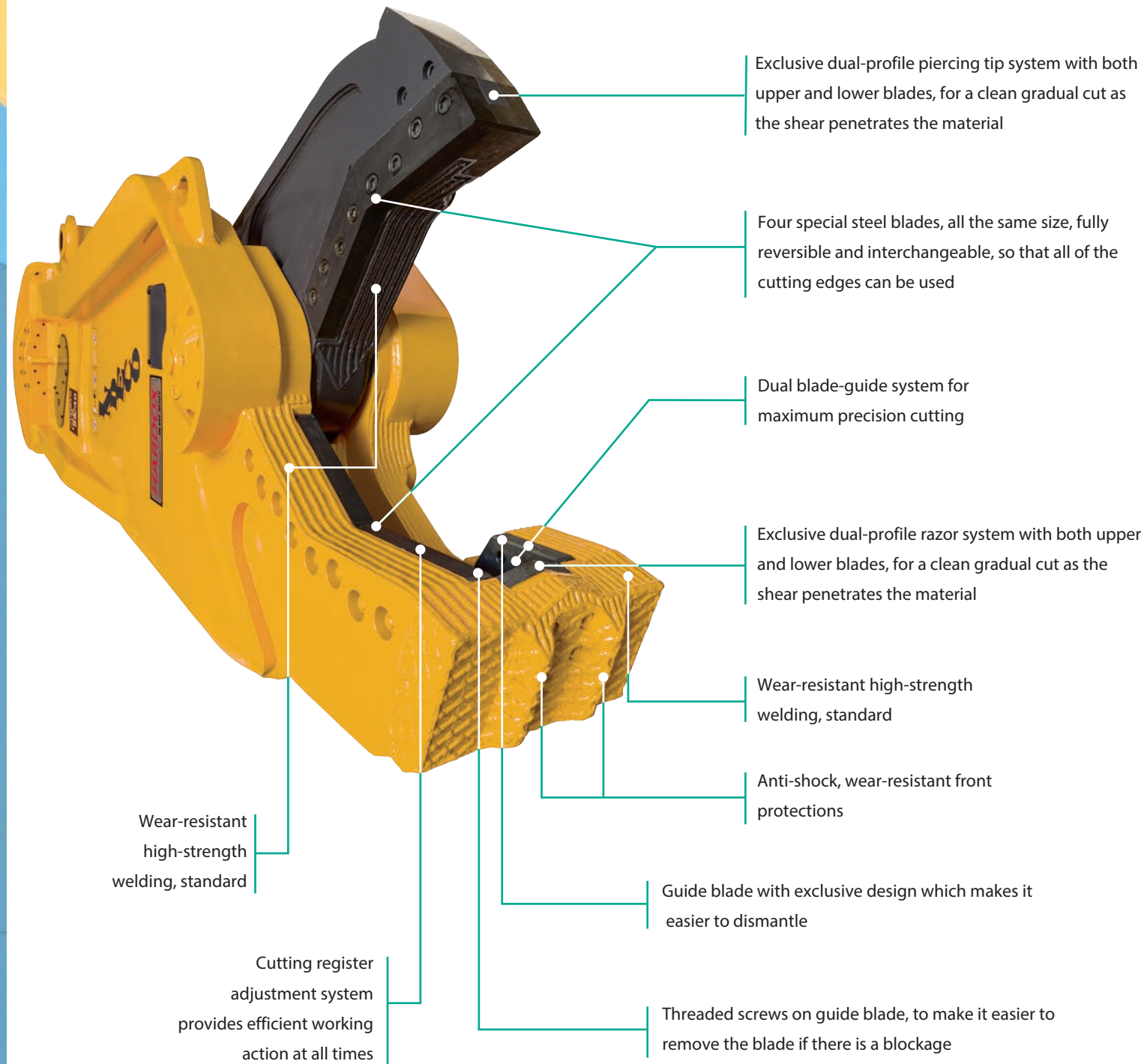

Technical Data	ISS 5/7	ISS 8/13	ISS 10/20
Type of carrier	1 2 3	1 2 3	4 5
Min. excavator weight in fixed version (boom-mounted) configuration	8800 lbs	13200 lbs	17600 lbs
Min. excavator weight in 2nd member (boom-mounted) configuration	11000 lbs	17600 lbs	22000 lbs
Min. excavator weight in 3rd member (bucket-mounted) configuration	15400 lbs	28600 lbs	44000 lbs
Attachment operating weight fixed version	1060 lbs	2300 lbs	4400 lbs
Attachment operating weight 2nd member	1250 lbs	2860 lbs	5280 lbs
Attachment operating weight 3rd member	1250 lbs	2750 lbs	5280 lbs
Maximum working pressure	4400 psi / 3200 psi*	5100 psi	5100 psi
Oil delivery	13 ÷ 32 gpm	24 ÷ 48 gpm	25 ÷ 55 gpm
Maximum rotation oil flow	3 gpm	4 gpm	5 gpm
Maximum rotation pressure	1650 psi	1650 psi	1650 psi
Maximum clamping force at tip	45 ton	80 ton	120 ton
Clamping force class	150 ton	300 ton	600 ton
Length	67 in	83 in	107 in
Jaw width	13.4 in	16 in	18 in
Jaw opening	13.8 in	18.5 in	22 in
Max jaw depth	12.6 in	18 in	22.5 in
Closure time	2 ÷ 3 s	2.9 ÷ 5 s	2.4 ÷ 4.6 s
Opening time	1 ÷ 1.6 s	1.5 ÷ 3 s	2.2 ÷ 4.2 s
Compatibility of attachment plate with hammer	HP 1250	HP 3000 - HP 4000	HP 5000 ÷ HP 7500

*Low pressure version

The information in this catalog is subject to change without notice and without any obligation or responsibility on our part. The content of this catalog is provided as a courtesy to readers and constitutes non binding information only.

Carrier key



Compact excavator



Miniloader



Backhoe loader



Wheeled excavator



Tracked excavator



ISS Fixed



ISS 2nd member



ISS 3rd member

Common configurations on the following models: ISS 5/7 - ISS 8/13 - ISS 10/20 - ISS 20/30 - ISS 25/40 - ISS 30/50 - ISS 35/60 - ISS 45/90

Technical Data	ISS 20/30	ISS 25/40	ISS 30/50
Type of carrier	5	5	5
Min. excavator weight in fixed version (boom-mounted) configuration	39600 lbs	50600 lbs	59400 lbs
Min. excavator weight in 2nd member (boom-mounted) configuration	44000 lbs	55000 lbs	66000 lbs
Min. excavator weight in 3rd member (bucket-mounted) configuration	66000 lbs	88000 lbs	110000 lbs
Attachment operating weight fixed version	7150 lbs	9900 lbs	12300 lbs
Attachment operating weight 2nd member	7920 lbs	11000 lbs	13860 lbs
Attachment operating weight 3rd member	8030 lbs	10560 lbs	13420 lbs
Maximum working pressure	5100 psi	5100 psi	5100 psi
Oil delivery	50 ÷ 80 gpm	55 ÷ 95 gpm	65 ÷ 105 gpm
Maximum rotation oil flow	8 gpm	11 gpm	13 gpm
Maximum rotation pressure	1650 psi	1650 psi	1950 psi
Maximum clamping force at tip	140 ton	195 ton	210 ton
Clamping force class	800 ton	1100 ton	1300 ton
Length	134 in	138 in	159 in
Jaw width	22 in	26 in	27 in
Jaw opening	26 in	30 in	33.5 in
Max jaw depth	27 in	30.5 in	34 in
Closure time	2.8 ÷ 4 s	3.2 ÷ 5 s	3.6 ÷ 5.8 s
Opening time	2.6 ÷ 3.8 s	2.8 ÷ 4.8 s	3.4 ÷ 5.6 s
Compatibility of attachment plate with hammer	HP 12000 - HP 14000	HP 12000 - HP 14000	HP 12000 - HP 14000

The information in this catalog is subject to change without notice and without any obligation or responsibility on our part. The content of this catalog is provided as a courtesy to readers and constitutes non binding information only.

Carrier key



Compact excavator



Miniloader



Backhoe loader



Wheeled excavator



Tracked excavator



ISS Fixed



ISS 2nd member



ISS 3rd member

Common configurations on the following models: ISS 5/7 - ISS 8/13 - ISS 10/20 - ISS 20/30 - ISS 25/40 - ISS 30/50 - ISS 35/60 - ISS 45/90

Technical Data	ISS 35/60	ISS 45/90
Type of carrier	5	5
Min. excavator weight in fixed version (boom-mounted) configuration	72600 lbs	92400 lbs
Min. excavator weight in 2nd member (boom-mounted) configuration	77000 lbs	99000 lbs
Min. excavator weight in 3rd member (bucket-mounted) configuration	132000 lbs	198000 lbs
Attachment operating weight fixed version	14960 lbs	21340 lbs
Attachment operating weight 2nd member	16500 lbs	24200 lbs
Attachment operating weight 3rd member	16720 lbs	22880 lbs
Maximum working pressure	5100 psi	5100 psi
Oil delivery	80 ÷ 145 gpm	95 ÷ 185 gpm
Maximum rotation oil flow	13 gpm	16 gpm
Maximum rotation pressure	1950 psi	1950 psi
Maximum clamping force at tip	240 ton	275 ton
Clamping force class	1500 ton	2500 ton
Length	161 in	190 in
Jaw width	30 in	32 in
Jaw opening	37.5 in	43.3 in
Max jaw depth	38.5 in	44 in
Closure time	3.6 ÷ 6.4 s	3.8 ÷ 7.2 s
Opening time	3.2 ÷ 5.6 s	3.6 ÷ 7 s
Compatibility of attachment plate with hammer	HP 16000 - HP 25000	HP 16000 - HP 25000

The information in this catalog is subject to change without notice and without any obligation or responsibility on our part. The content of this catalog is provided as a courtesy to readers and constitutes non binding information only.

Carrier key



Compact excavator



Miniloader



Backhoe loader



Wheeled excavator



Tracked excavator



ISS Fixed



ISS 2nd member



ISS 3rd member

Common configurations on the following models: ISS 5/7 - ISS 8/13 - ISS 10/20 - ISS 20/30 - ISS 25/40 - ISS 30/50 - ISS 35/60 - ISS 45/90

Appetite guide

Indeco shears are designed to cut and reduce the size of the most common materials used in demolitions in the mechanical, naval and construction sectors. The figures set out below refer to cutting capacity under normal working conditions. Results may vary according to such factors as

how robust the material to be cut is, what condition the shear blades are in, the characteristics of the carrier and the operator's ability. Appropriate maintenance of the shear is crucial for maximum productivity of cutting operations.

	ISS 5/7	ISS 8/13	ISS 10/20	ISS 20/30	ISS 25/40	ISS 30/50	ISS 35/60	ISS 45/90
●	0.8 in	1.4 in	2 in	2.8 in	3.6 in	4.2 in	4.6 in	5.7 in
◎	2.5 in*	8 in*	10.5 in*	13 in*	17.5 in*	19.5 in*	22.5 in*	28 in*
■	0.8 in	1.6 in	2 in	2.5 in	3.5 in	4 in	4.5 in	5.5 in
▬	0.25 in**	0.4 in**	0.5 in**	0.75 in**	0.8 in**	0.9 in**	1 in**	1.25 in**
I	5 IPE***	8.5 IPE***	13 IPE***	16 IPE***	18 IPE***	20 IPE***	22 IPE***	24 IPE***
I	4 HEA	8 HEA	10 HEA	12 HEA	13.5 HEA	14 HEA	16 HEA	18 HEA
I	6 I BEAM (W)	10 I BEAM (W)	13 I BEAM (W)	16 I BEAM (W)	18 I BEAM (W)	22 I BEAM (W)	26 I BEAM (W)	31 I BEAM (W)
I JIS G3192	4x4x0.8	8x8x2	10x10x3	12x12x4	16x12x4	18x12x5	20x12x5	24.5x12x5

*Refer to mild steel tubing and not to other materials such as stainless steel, cast steel etc.

**Blade thickness affect the shear's capacity to pierce sheet metal in various applications

***These figures may vary for beams of different shapes, thicknesses and material



Features of Indeco rail cutters

Structure **[1]** with an extremely robust design, entirely made of HARDOX® 450 to withstand the strong stresses of very heavy-duty work, and particularly compact to facilitate coupling with machines with a wider weight range.

Large hydraulic cylinder **[2]**, to provide greater power and to respond to the heaviest stresses, equipped with metal alloy sliding components to ensure maximum reliability.

Wider maximum opening **[3]** than competitors, for greater flexibility, being able to 'process' rails with the most diverse profiles and dimensions on the global market.

The cutters **[4]** in special hardened material, interchangeable and rotatable, can be used up to 4 times in order to always have efficient cutting angles.

The specific design of the claws **[5]** and of the cutter profiles enables the cutting of rails up to 47 lb/ft mass per meter and up to 300 Brinell hardness. and up to 300 Brinell hardness.

The 'quick change' interchangeable wear bushings **[6]** make it so that the cutters are always aligned optimally.

The exceptionally robust pivoting system **[7]** ensures long-lasting cutting efficiency and keeps the jaws aligned, preventing twisting.

Efficient and easily accessible hydraulic system **[8]**.

Full 360° hydraulic rotation system **[9]** for greater flexibility and speed. Equipped with relief valves for flow and pressure, it guarantees greater reliability, durability, and positioning precision.

The attachment plate **[10]** is compatible with that of Indeco hammers of the same weight.

The 3rd-member mounting bracket **[11]** lets you mount the IRC on the carrier stick (bucket-mounted) of the excavator.

The 2nd-member mounting bracket **[12]** lets you mount the IRC directly onto the excavator boom. In this configuration, large equipment can be mounted even on a low weight machine. The universal attachment plate for 2nd-member mounting brackets **[13]** is compatible with all excavators.

2nd and 3rd member configuration

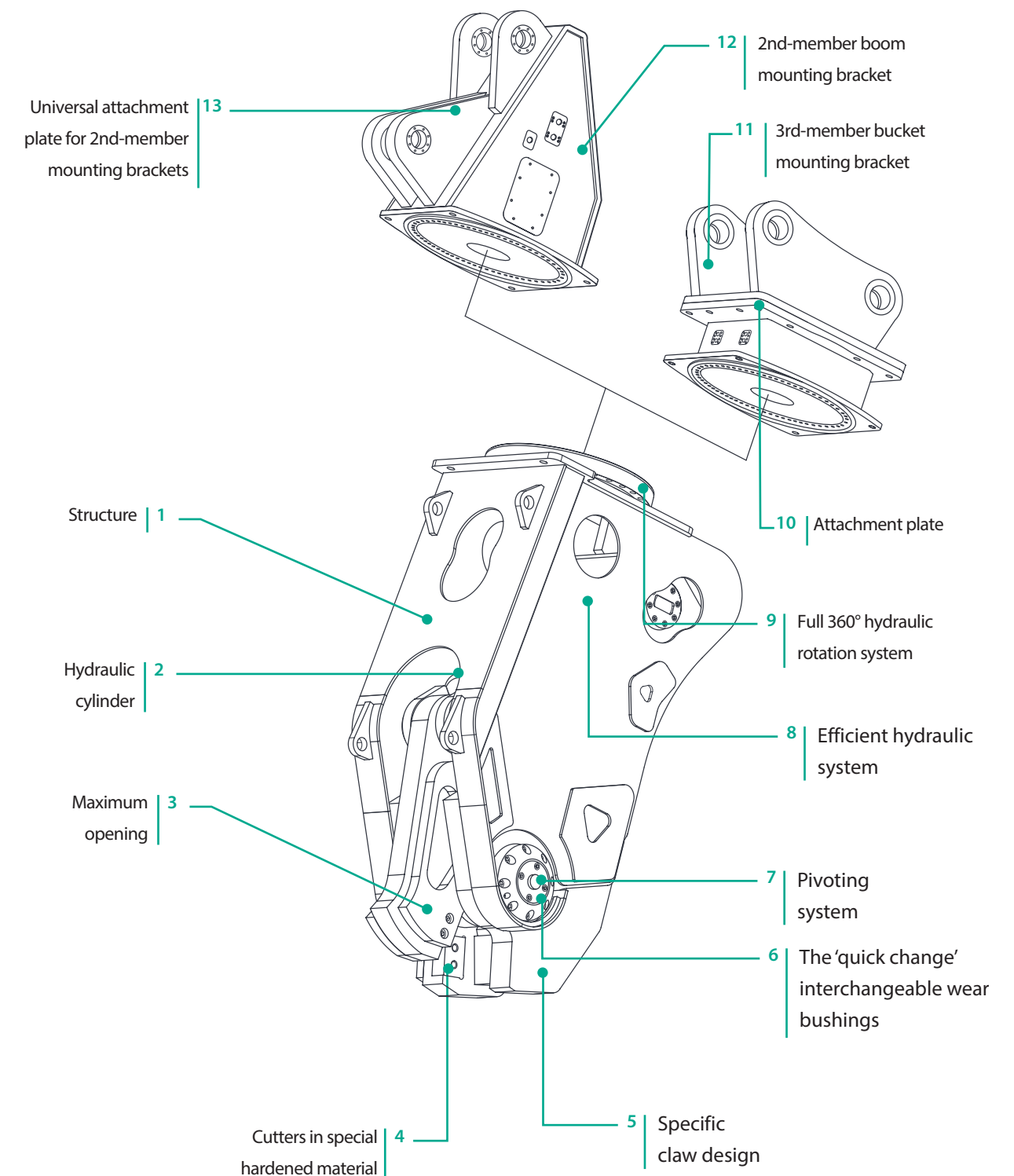

Technical Data	IRC 30
Type of carrier	5
Min. excavator weight in 2nd member (boom-mounted) configuration	44000 lbs
Min. excavator weight in 3rd member (bucket-mounted) configuration	66000 lbs
Attachment operating weight 2nd member	9650 lbs
Attachment operating weight 3rd member	9240 lbs
Maximum working pressure	5150 psi
Oil delivery	66 ÷ 106 gpm
Maximum rotation oil flow	8 gpm
Maximum rotation pressure	1620 psi
Maximum clamping force at tip	550 ton
Clamping force class	1000 ton
Length	104 in
Jaw width	29 in
Jaw opening	9 in
Max jaw depth	9.1 in
Closure time	3 ÷ 5 s
Opening time	2 ÷ 3 s
 Rail (<300HB)	47 lb/ft
Compatibility of attachment plate with hammer	HP 10000



IRC 3rd member

The information in this catalog is subject to change without notice and without any obligation or responsibility on our part. The content of this catalog is provided as a courtesy to readers and constitutes non binding information only.

Carrier key



Compact excavator



Miniloader



Backhoe loader



Wheeled excavator



Tracked excavator

Accessories

1 | Indeconnect system

New remote monitoring system, based on the principles of the Internet of Things, to prevent equipment obsolescence and keep high performance. The 'Indeconnect' system consists of a **device** equipped with 4G technology for a wireless connection to the network, to be mounted on the equipment, and a cloud-based **web platform** you can access from mobile devices (with an app) or from PC, that lets you view the data transmitted in real time by each installed device: working hours, working position in space, hydraulic oil temperature, ambient temperature, GPS position, and more.

Through Indeconnect you can:

- **Monitor productivity**, making sure each Indeco tool is working as intended
- **Check operations**, verifying in real time the various internal and external parameters of the equipment to make sure that it is used in optimal conditions and correctly
- **Increase security**, by remotely checking the position of the equipment through GPS
- **Plan maintenance**, monitoring the health of each Indeco tool in real time, also through the automatic alert and messaging system that lets you order spare parts and reduce machine downtime to a minimum
- **Optimise rental**, by supervising and monitoring the management of rented equipment.

2 | Connecting hoses

We recommend using original Indeco high- and low-pressure hoses to connect various tools to the hydraulic system on the carrier.

3 | Special 2nd member universal mounting bracket

Indeco has designed our second-member mounting system to be flexible, extremely strong, long-lasting and suitable for a variety of different carriers. Digitally-machined true surfaces ensure perfect alignment of the rotating

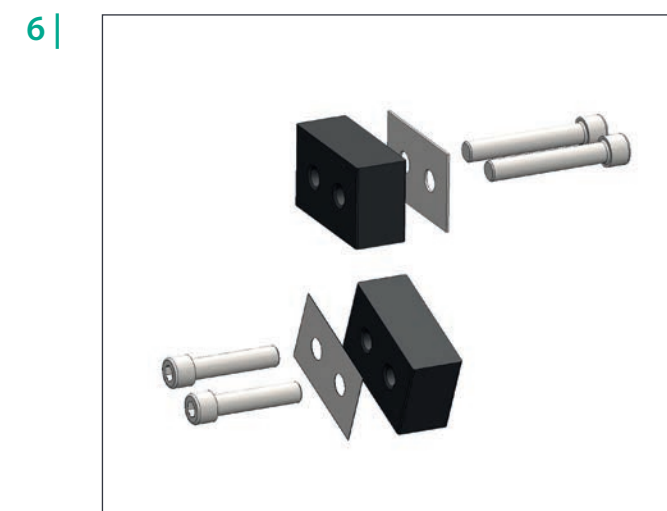
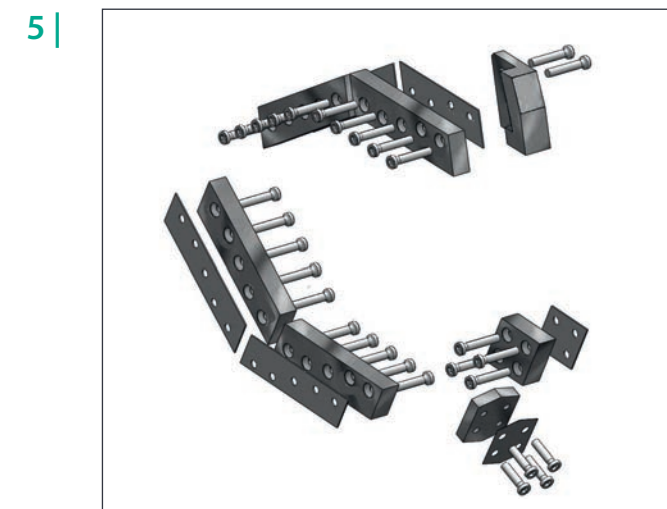

components and all service items are easily accessed via the four access panels.

4 | Mounting bracket for 3rd member configuration

Indeco has designed our 3rd member mounting brackets to give the operator the best flexibility in terms of range of reach and positioning. They are designed identically to OEM bucket dimensions with pre-installed pins; allowing for quick change as needed and the use of quick-coupler systems if desired.

5 | ISS blades

ISS blades are made with special heat-treated steels, using an exclusive Indeco technology which optimizes their performance and durability.

6 | IRC blades

Specially designed and heat-treated to cut rails of any size. Interchangeable and reversible, they can be used on all four sides.

Application areas



Demolition & Renovation



Recycling

		ISS			IRC	
		F	II	III	II	III
Light demolition	<ul style="list-style-type: none"> Demolition of masonry structures Brickwork Natural stone Renovation of interiors Autoclaved aerated concrete 					
Demolition of non-reinforced concrete structures	<ul style="list-style-type: none"> Primary demolition of lightweight and standard concrete Primary demolition of heavyweight concrete Wall elements Secondary demolition 					
Composite steel & concrete structure demolition	<ul style="list-style-type: none"> Primary demolition of lightweight and standard reinforced concrete Primary demolition of heavyweight steel-reinforced concrete Secondary demolition floors, slabs and beams Separating rebars from pillars and struts Fiber-reinforced concrete Cutting rebars and steel reinforcements 					
Demolition of metallic buildings and structures	<ul style="list-style-type: none"> Demolition of refineries Cutting of metal and steel structures Cutting steel girders/beams Cutting reinforcements 		○	○		
Sorting and loading	<ul style="list-style-type: none"> Sorting Loading Waste handling Site clean-up 	○	○	○		
Pavement demolition	<ul style="list-style-type: none"> Asphalt Concrete Composite surfaces 					
Processing	<ul style="list-style-type: none"> Scrap material processing Cutting tires Processing rail cars Processing cars, trucks and general automotive Cutting tanks Cutting of railway tracks, tramway rails, and underground rails 	○	○	○		
Handling and sorting	<ul style="list-style-type: none"> Scrap material handling Scrap material sorting Urban waste Industrial waste Wood and tires 		○	○		
Downsizing and sorting	<ul style="list-style-type: none"> Material downsizing and sorting in recycling quarries 				○	○
Recycling of ferrous material	<ul style="list-style-type: none"> Recycling of ferrous material 	○	○	○	○	○
Car dismantling	<ul style="list-style-type: none"> Material handling and sorting 					



F| Fixed configuration II| Second-member configuration III| Third-member configuration

The complete range of Indeco products

Products	Weight/Length	Products	Weight/Length
HP Hydraulic hammers	from 135 to 24400 lbs	IHC R rotating compactors	from 950 to 3350 lbs
IFP fixed pulverisers	from 1650 to 10050 lbs	IMG S-D-H-L-T Multi Grabs	from 630 to 6600 lbs
IRP rotating pulverisers	from 1300 to 9900 lbs	ISS Shears	from 1060 to 24200 lbs
IDC Primary Demolition Crusher	from 1980 to 15850 lbs	IRC rail cutters	from 9240 to 9650 lbs
IMP Multiprocessor	from 3300 to 10800 lbs	IMH Mulching Heads	from 850 to 4250 lbs
IMP Mutiprocessor Car Dismantler	3300 lbs	IBS boom systems	from 11 to 47 ft
IHC fixed compactors	from 450 to 2850 lbs		

*Lengths can be customised on the basis of the customer's needs.

USA Version



INDECO North America

135 Research Drive
Milford CT, 06460

PH. (203) 713-1030 - F (203) 713-1040

www.indeco-breakers.com

Quality Management
System Certification
UNI EN ISO 9001:2015



Member of



AUTHORISED DEALER