

Hydraulic hammers

HP Series



 **INDECO**
A TOOL FOR EVERY JOB



Hydraulic hammers Indeco HP

Indeco HP hydraulic hammers are an outstanding expression of Italian high-tech and construction quality applied to demolition. In-depth research into hydraulic systems, materials, heat treatment and accessories have enabled Indeco to establish a reputation in markets throughout the world for product excellence.

With its many different models, divided into large, medium and small and available in various versions, Indeco has the widest range of hammers available anywhere in the world. This provides end-users with a huge choice, ensuring that they can find the ideal hammer/excavator match.





Small hammers

Despite their compact size, Indeco's range of small hammers are exceptionally reliable, quiet and efficient, and best suited for such jobs as excavations work, highway maintenance, demolitions and recycling in city areas and building refurbishment. Their versatility makes them extremely efficient in specialist jobs such as maintenance in iron foundries.



Medium hammers

Their excellent weight/power ratio and their slimline structure make the mid-range Indeco hammers the ideal choice for classical applications, such as demolishing buildings, earthworks in inhabited areas and secondary demolitions in quarries, as well as for more specific tasks. In fact, mid-range hammers are used for underwater work (using a special kit) as well as for digging narrow deep trenches and removing casting slag from blast furnaces.



Large hammers

Combining maximum power with the effectiveness of intelligent technology, Indeco's larger hammers are unbeatable when it comes to completing the toughest jobs in the shortest possible time-frame – whether it's the biggest demolition jobs, primary breaking in quarries, digging foundations, or excavating huge rail and road tunnels.



Features of Indeco hammers

All Indeco hammers have a special intelligent hydraulic system **[1]**, enabling them to automatically vary the energy and frequency of the blows according to the hardness of the material being demolished.

This optimises the hydraulic pressure delivered by the machine, thus improving productivity and enhancing the overall performance.

Exclusive features such as the synchronised internal distributor **[2]** aligned with the piston, the oil cushions **[3]** for vibration dampening and the short hydraulic flow pattern **[4]** make it possible to completely do away with seals in the distribution area, a decisive factor in extending the working life of the hammer and significantly reducing downtimes.

The use of special low-alloy steels, exclusively manufactured according to Indeco's own formula greatly lengthen the average working life of the major hammer components.

The housing **[5]** is made out of extra-strength HARDOX® steel wear plates, which eliminate buckling.

The piston **[6]** is divided into two parts, for greater impact energy and lower operating costs.

The centralised greasing system **[7]** enables the sliding parts to remain lubricated even when the hammer is operating horizontally, thus considerably reducing wear and tear on components and extending product lifetime.

The “quick change” interchangeable bushing **[8]** is available in various materials for different jobs; it is inserted into the lower tool bushing where the tool moves, and reduces maintenance times and costs, by cutting out the long machine downtimes needed to replace the traditional fixed bushing.

All carriers which mount Indeco hammers benefit from the Indeco dual shock-absorption system **[9]**: an internal hydraulic one and a mechanical one, located outside the body, which substantially reduce the vibrations transmitted to the excavator.

The excavator boom is also subject to lower stress levels, as Indeco hammers are considerably lighter under working conditions than rival makes in the same class. Alongside the standard versions there is also a super-soundproofed

Whisper version, whose body is lined internally with sound-absorbent material **[10]** and an “anti-rumble” paint, which – combined with a few modifications to the bushing – enable noise emission levels to be considerably reduced.

By lowering pressure peaks, the rechargeable hydraulic/nitrogen accumulator **[11]** also reduces stress in the excavator hydraulic circuit, keeps the gas charge and energy per blow constant, and reduces maintenance and operating costs.



The ABF (Anti Blank Firing) system **[12]**, installed as standard on all of the medium- and large-range Indeco hammers, cuts out blank fire by eliminating any down pressure from the hammer whenever the tool is not resting firmly on the surface to be demolished.

This increases the service life of all components subject to wear and tear, as well as reducing stress to the hammer body and excavator arm.



As well as being efficient and reliable, Indeco hydraulic hammers are now proving to be even more environmentally-friendly and low on fuel consumption. With a now even more efficient hydraulic system **[13]**, the HP series has now also become FS (Fuel Saving). Compared to other manufacturers' models of equivalent weight and performance, Indeco hammers require less oil per minute and lower operating pressure. And as using lower hydraulic power means reducing the number of revolutions per minute on the carrier, they lead to fuel savings of up to 20%, while ensuring optimum performance and maximum productivity. This becomes even more evident when comparing the Indeco hammer with gas or gas/oil powered products of similar size manufactured by competitors.

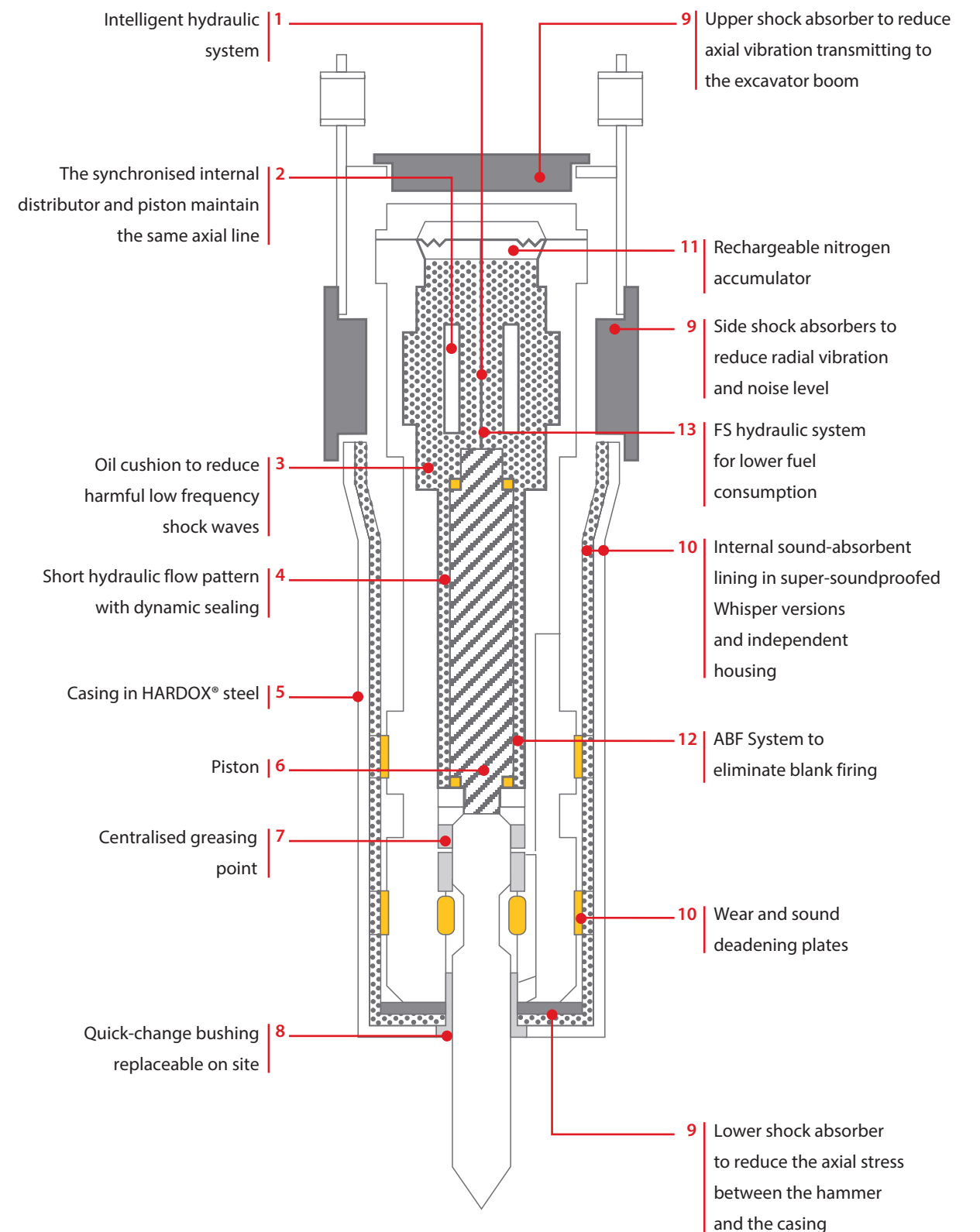

Small hammer range

HP series

These excellent jobsite companions are the most numerous class of models in the Indeco range.



Technical Data	HP 150 FS	HP 200 FS / HP 200 FS Heavy Duty	HP 350 FS	HP 550 FS
Type of carrier	1 2	1 2	1 2	1 2 3
Excavator weight (possible)	1150 ÷ 4450 lbs	1550 ÷ 6650 lbs	3100 ÷ 11000 lbs	3750 ÷ 14300 lbs
Weight of hammer when operated	135 lbs	180 / 220 lbs (Heavy Duty)	360 lbs	510 lbs
Tool diameter	1.66 in	1.80 in	1.90 in	2.60 in
Pressure adjusted to the excavator	2400 psi	2400 psi	2400 psi	2400 psi
Back pressure max	240 psi	160 psi	150 psi	170 psi
Energy class per blow	150 lb.ft	200 lb.ft	350 lb.ft	550 lb.ft
Number of blows per minute	400 ÷ 1900 bpm	540 ÷ 2040 bpm	700 ÷ 1800 bpm	540 ÷ 1670 bpm

HP 800 FS	HP 1000 FS	HP 1100 FS	HP 1250 FS
1 2 3	1 2 3	1 3	1 3
6650 ÷ 19800 lbs	7750 ÷ 23100 lbs	8850 ÷ 26450 lbs	11050 ÷ 30850 lbs
710 lbs	860 lbs	980 lbs	1220 lbs
3 in	3 in	3.15 in	3.55 in
2400 psi	2500 psi	2500 psi	2500 psi
170 psi	160 psi	170 psi	160 psi
800 lb.ft	1000 lb.ft	1100 lb.ft	1250 lb.ft
780 ÷ 1720 bpm	600 ÷ 1340 bpm	620 ÷ 1500 bpm	570 ÷ 1180 bpm

Carrier key



Compact excavator



Miniloader



Backhoe loader



Wheeled excavator



Tracked excavator

For data on the pressure adjusted to the hammer and on oil flow, please consult the "Parameters for selecting and adjusting the hammer" page.

The information in this catalog is subject to change without notice and without any obligation or responsibility on our part. The content of this catalog is provided as a courtesy to readers and constitutes non binding information only.

Medium hammer range

HP series

A perfect blend of power and agility characterises the mid-range Indeco hammers, tireless partners even on the toughest of jobs.



Technical Data	HP 1500 FS	HP 1800 FS	HP 2000 FS	HP 3000 FS
Type of carrier	1 3 4	4 5	4 5	4 5
Excavator weight (possible)	14400 ÷ 35200 lbs	22100 ÷ 44000 lbs	26500 ÷ 48500 lbs	33000 ÷ 55000 lbs
Weight of hammer when operated	1440 lbs	1880 lbs	2250 lbs	2650 lbs
Tool diameter	3.55 in	4.30 in	4.55 in	4.80 in
Pressure adjusted to the excavator	2500 psi	2700 psi	2700 psi	2700 psi
Back pressure max	120 psi	140 psi	120 psi	120 psi
Energy class per blow	1500 lb.ft	1800 lb.ft	2000 lb.ft	3000 lb.ft
Number of blows per minute	450 ÷ 980 bpm	420 ÷ 1000 bpm	440 ÷ 1060 bpm	460 ÷ 940 bpm

HP 4000 FS	HP 4500 FS	HP 5000 FS
4 5	5	5
35500 ÷ 61500 lbs	35500 ÷ 66000 lbs	42000 ÷ 70500 lbs
3320 lbs	3740 lbs	4200 lbs
5.10 in	5.35 in	5.55 in
2700 psi	2800 psi	3000 psi
100 psi	100 psi	120 psi
4000 lb.ft	4500 lb.ft	5000 lb.ft
400 ÷ 870 bpm	400 ÷ 870 bpm	360 ÷ 870 bpm

Carrier key



For data on the pressure adjusted to the hammer and on oil flow, please consult the "Parameters for selecting and adjusting the hammer" page.

The information in this catalog is subject to change without notice and without any obligation or responsibility on our part. The content of this catalog is provided as a courtesy to readers and constitutes non binding information only.

Large hammer range

HP series

This is the most prestigious class, containing the top range of Indeco hammers. They are top hammers not only in terms of size, but also in their outstanding performance.



Technical Data	HP 6000 FS	HP 7500 FS	HP 10000 FS	HP 11000 FS
Type of carrier	5	5	5	5
Excavator weight (possible)	46500 ÷ 84000 lbs	51000 ÷ 93000 lbs	60000 ÷ 110000 lbs	66500 ÷ 121000 lbs
Weight of hammer when operated	5000 lbs	5550 lbs	6950 lbs	7950 lbs
Tool diameter	5.75 in	5.95 in	6.30 in	6.70 in
Pressure adjusted to the excavator	3100 psi	3100 psi	3100 psi	3100 psi
Back pressure max	100 psi	120 psi	100 psi	100 psi
Energy class per blow	6000 lb.ft	7500 lb.ft	10000 lb.ft	11000 lb.ft
Number of blows per minute	370 ÷ 760 bpm	340 ÷ 820 bpm	300 ÷ 670 bpm	300 ÷ 650 bpm

HP 12000 FS	HP 14000 FS	HP 16000 FS	HP 25000 Plus FS
5	5	5	5
75000 ÷ 138000 lbs	86000 ÷ 175000 lbs	100000 ÷ 265000 lbs	132000 ÷ 310000 lbs
9900 lbs	11600 lbs	17200 lbs	24400 lbs
7.10 in	7.70 in	8.50 in	10 in
3100 psi	3100 psi	3400 psi	3400 psi
120 psi	120 psi	130 psi	160 psi
12000 lb.ft	14000 lb.ft	16000 lb.ft	25000 lb.ft
320 ÷ 580 bpm	270 ÷ 540 bpm	240 ÷ 550 bpm	240 ÷ 460 bpm

Carrier key



Compact excavator



Miniloader



Backhoe loader



Wheeled excavator



Tracked excavator

For data on the pressure adjusted to the hammer and on oil flow, please consult the "Parameters for selecting and adjusting the hammer" page.

The information in this catalog is subject to change without notice and without any obligation or responsibility on our part. The content of this catalog is provided as a courtesy to readers and constitutes non binding information only.

Productivity

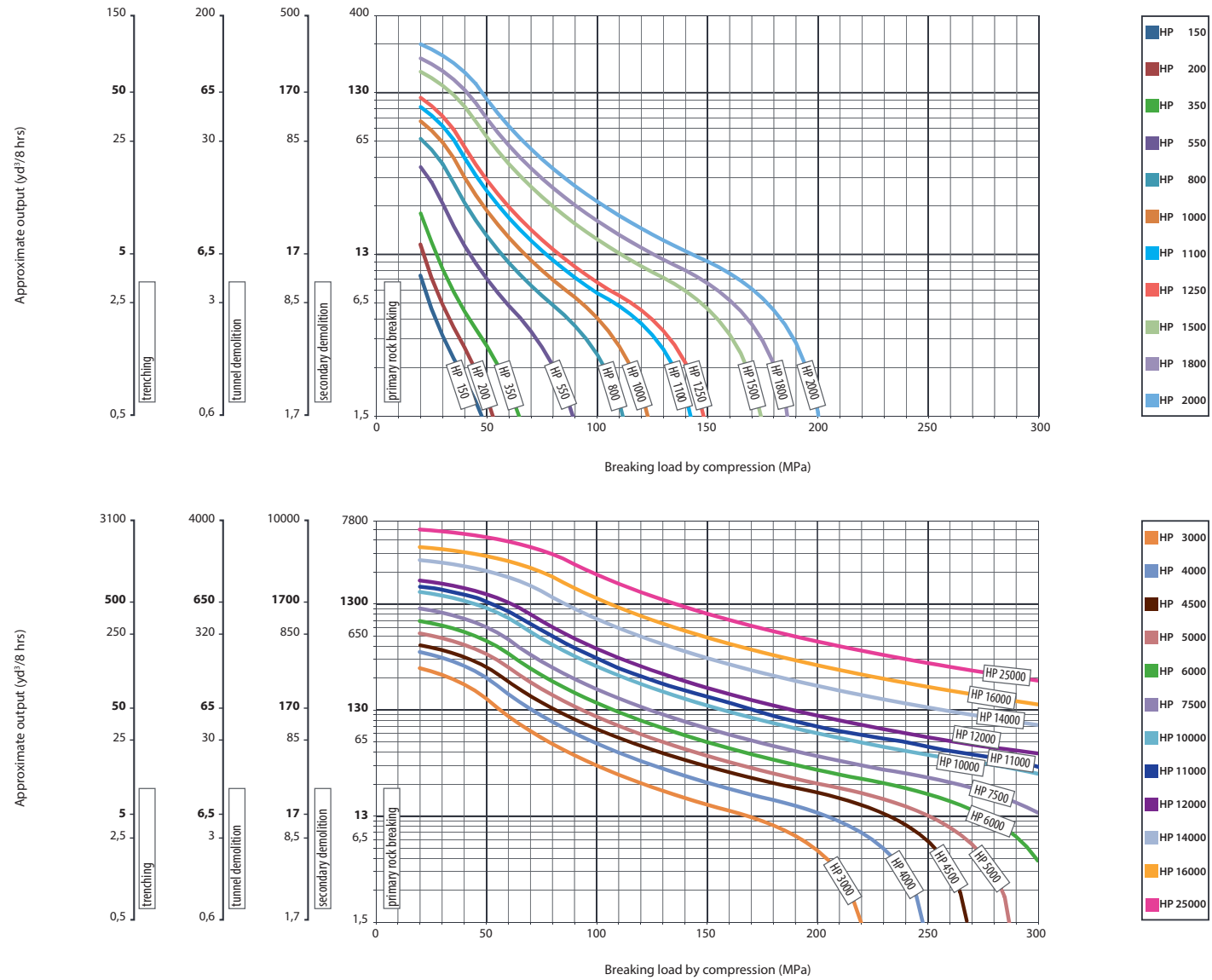

N.B. These nominal values are for reference purposes and are not binding

Noise levels

Noise levels measured* at various distances

Distance	33 ft	50 ft	65 ft	80 ft	100 ft
All HP models	96*	92.5*	90*	88.1*	86.5*

*values expressed in dB (A)

Noise level guaranteed* by the 2006/42/CE directive

All HP models	126*
---------------	------

Parameters for selecting and adjusting the hammer

Model	Compatibility hammer/carrier (lbs)*	Pressure regulation values (psi)/oil flow (gpm)**
HP 150	1150 4450	1550 1650 1750 1800
	1550 4000	7.4 5.3 4 2.7
HP 200	1550 6650	1550 1650 1750 1800
	1800 5550	11 8 6 4
HP 350	3100 11000	1550 1650 1750 1800
	4450 8800	12 10 7 7
HP 550	3750 14300	1550 1650 1750 1800
	5550 11000	18 12 10 8
HP 800	6650 19800	1550 1650 1750 1800
	7750 16500	23 19 16 14
HP 1000	7750 23100	1550 1700 1800 1850
	8850 18700	22 19 16 14
HP 1100	8850 26450	1550 1700 1800 1850
	12150 22000	24 22 19 16
HP 1250	11050 30850	1550 1700 1800 1850
	13250 26450	27 24 22 19
HP 1500	14400 35200	1550 1700 1800 1850
	17700 28600	28 26 23 19
HP 1800	22100 44000	1700 1700 1850 2000
	26500 37400	34 30 27 22
HP 2000	26500 48500	1700 1700 1850 2000
	31000 44000	35 32 30 23
HP 3000	33000 55000	1700 1800 1900 2000
	39500 48500	40 36 34 30
HP 4000	35500 61500	1700 1800 1900 2000
	42000 52500	43 37 35 34
HP 4500	35500 66000	1750 1850 2000 2100
	44500 57000	43 39 36 35
HP 5000	42000 70500	1850 1950 2050 2150
	46500 61500	48 45 43 39
HP 6000	46500 84000	1900 1950 2050 2300
	53000 66000	53 49 47 43
HP 7500	51000 93000	1900 2000 2150 2300
	57500 72500	61 57 55 48
HP 10000	60000 110000	1900 2000 2150 2300
	66500 88000	71 61 59 51
HP 11000	66500 121000	1900 2000 2150 2300
	77500 99000	74 64 61 53
HP 12000	75000 138000	2050 2100 2200 2350
	79000 115000	81 76 73 67
HP 14000	86000 175000	2050 2150 2250 2350
	101000 150000	94 86 84 77
HP 16000	100000 265000	2050 2300 2400 2600
	128000 198000	111 101 98 86
HP 25000	132000 310000	2050 2300 2500 2600
	165000 265000	138 125 122 111

*Suggested uses on machines with an overall weight (lbs):

Best Possible (match subject to approval by the Indeco dealer)

**Pressure adjusted to the hammer (psi) relative to oil flow (gpm):

Optimum pressure adjusted to the hammer (psi) Optimal oil supply (gpm) Possible pressure/oil

Accessories

Indeconnect system

New remote monitoring system, based on the principles of the Internet of Things, to prevent equipment obsolescence and keep high performance.

The 'Indeconnect' **[1]** system consists of a **device** equipped with 4G technology for a wireless connection to the network, to be mounted on the equipment, and a cloud-based **web platform** you can access from mobile devices (with an app) or from PC, that lets you view the data transmitted in real time by each installed device: working hours, working position in space, hydraulic oil temperature, ambient temperature, GPS position, and more.

Through Indeconnect you can:

- **Monitor productivity**, making sure each Indeco tool is working as intended
- **Check operations**, verifying in real time the various internal and external parameters of the equipment to make sure that it is used in optimal conditions and correctly
- **Increase security**, by remotely checking the position of the equipment through GPS
- **Plan maintenance**, monitoring the health of each Indeco tool in real time, also through the automatic alert and messaging system that lets you order spare parts and reduce machine downtime to a minimum
- **Optimise rental**, by supervising and monitoring the management of rented equipment.

IDA (Indeco Dust Abatement) System

An innovative system that is particularly effective for reducing wear and tear on components, extending the working life of the hammer and protecting operators against exposure to microparticles of crystalline silica. It consists of a jet of high-pressure water spray, emitted by a number of nozzles **[2]** on the casing, which prevents dust from harming both the tool and the operator.

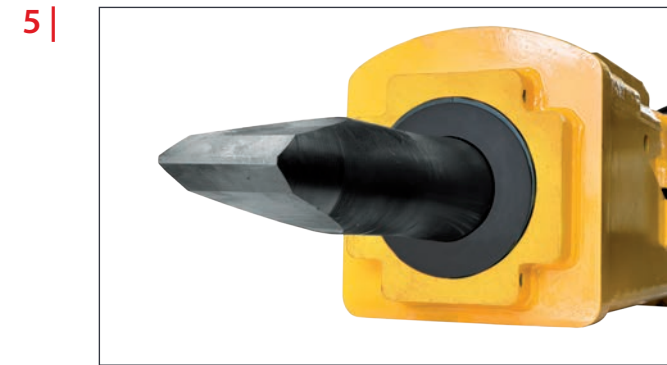
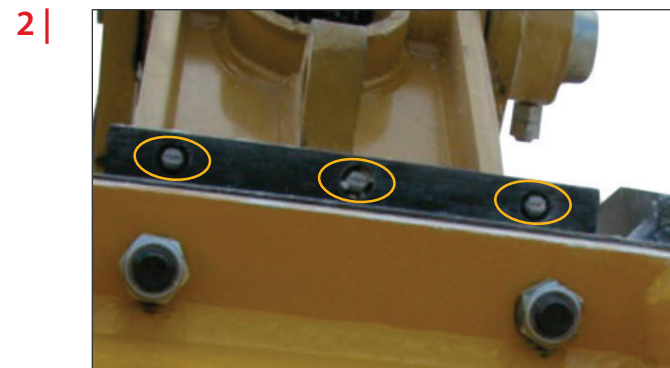
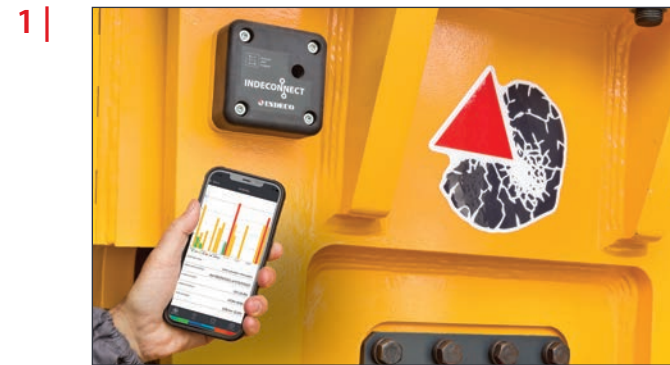

Recently updated to comply with the latest OSHA directives, the system is available in two different versions:

• High-pressure system

Available for medium-large to large hammers, it is made up of an air compressor and a high-pressure water pump, mounted onto the excavator and driven by two hydraulic motors powered by the excavator. A set of electrohydraulic valves enable the excavator operator to activate the pump and compressor independently, thus starting up either one or both of the protection devices: the dust-abatement kit, which uses a fine water spray and the dust shield, which uses the internal pressurization of the hammer **[3]** to prevent dust, water and debris from getting into the hammer through the bushing, as can occur during tunnel demolitions and underwater excavations.

• Low-pressure system

Designed for smaller hammers and pulverizers, the technology involves inserting a vaporizing plate with four nozzles **[4]**, where the mounting bracket is attached, which enables it to cover the whole working area (whatever position it is in) and reduce the amount of dust produced, even on windy days. The new system only needs a low-pressure water supply and the sprayers turn on automatically only when the attachment is in action, thus also reducing water consumption.

Anti-Grease and Anti-Dust System

This system, which is crucial when working in dusty environments and when tunnelling, is made up of two collars. Both are adherent to the tool **[5]**, and which prevent dust from getting in and grease from getting out, improving lubrication levels and thus lengthening the working life of the main hammer components.

Indeco Lube automatic greasing systems

Among the most important accessories for hydraulic hammers, automatic greasing systems developed by Indeco technical staff are designed to keep hammers in perfect working order at all times, by using just the right amount of lubricant and avoiding machine downtime necessary for manual greasing operations by the operator. There are two types of greasing unit – either an on-board system that can be fitted directly onto the hammer and which uses a cartridge pump, or else an excavator-mounted unit with its own grease tank [6]. In both cases, these systems are connected to the hammer through a single centralized greasing point [7], which enables the lubricant to reach all of the bushings and the moving parts at the tool, inside the hammers and on the retaining axle.

On-Board greasing systems

- **“Small”** with a “one shot” pump, only one HYD line, [8] and a single 200 g or 400 g cartridge for hammers from HP 350 to HP 2000
- **“Compact”** with a “one shot” pump, only one HYD line, and a single 400 g cartridge [9] for hammers from HP 3000 to HP 12000
- **“Maxi”** with two “one shot” pumps, only one HYD line, and two 400 g cartridges [10] for hammers from HP 14000 to HP 25000

Carrier-mounted systems

- 1.6 gal hydraulically or electrically-operated tank
- 5.8/6.6 gal drumimmersion pump and hydraulic or electric action

Special Indeco Supreme lubricant

It is vital that a specific lubricant be used to ensure the durability of the main components of the hammer. Indeco’s [11] Supreme lubricant, with solid additives is

9 |



10 |



11 |



12 |

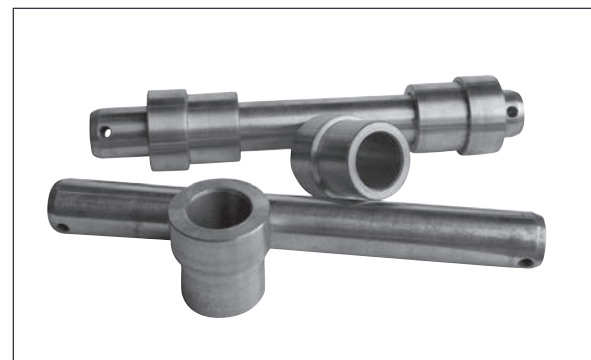

13 |

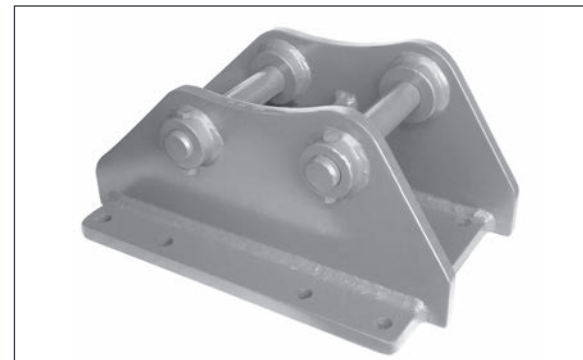

14 |



15 |



particularly resistant to oxidation, can withstand extreme pressures and temperatures and shows excellent adhesion and water-resistance.

Pins and bushings

[12] Designed to make it easier to mount all Indeco products onto the excavator boom, with or without a mounting bracket.

Mounting brackets

Each Indeco mounting bracket model [13] can be used with all Indeco products in the same class.

Folding mounting bracket

A special mounting bracket [14] for folding the hammer away directly under the carrier boom.

Connecting hoses

We recommend using original Indeco high- and low-pressure hoses [15] to connect various tools to the hydraulic system on the carrier.

The tools

Chisel tool

Suitable for all earthworking or narrow-section excavation jobs on medium to hard stratified rock.



Moil point tool

Suitable for breaking up concrete or medium-hard, non-stratified rock. Secondary demolition: average, hard or extremely hard blocks.



Asphalt cutter / shovel tool

For cutting or breaking the road surface, breaking floors, walls, brick or tuff walls. Available in the in-line (asphalt cutter) and 90° transversal (shovel) versions according to the working direction.

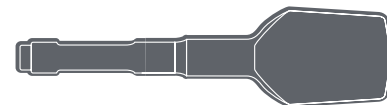

Pile driver

Suitable for pilework or press-moulded supports for guardrails, etc.



Pyramidal point

Suitable for demolishing hard reinforced concrete flooring, as well as sedimentary material.



Cobra chisel tool

Suitable for all types of excavation work on medium-hard to hard rock, non-stratified rock or rock which tends to pulverise when being broken up, puddingstones.





Blunt tool

Suitable for breaking up blocks of any hardness, or to reduce the size of rubble.



Application areas

		L	M	S	
 Mining and Quarry	Preliminary works	<ul style="list-style-type: none"> Overburden removal Bench, road & ramp leveling Roof, face & rib scaling 	<input type="radio"/>	<input type="radio"/>	<input type="radio"/>
	Secondary demolition	<ul style="list-style-type: none"> Boulder reduction in rock pile Removing blockages at crushing systems 	<input type="radio"/>	<input type="radio"/>	<input type="radio"/>
	Primary rock breaking	<ul style="list-style-type: none"> Selective rock breaking Blastfree mining 	<input type="radio"/>	<input type="radio"/>	<input type="radio"/>
 Demolition & Renovation	Light demolition	<ul style="list-style-type: none"> Demolition of masonry structures Brickwork Natural stone Renovation of interiors Autoclaved aerated concrete 	<input type="radio"/>	<input type="radio"/>	<input type="radio"/>
	Demolition of non-reinforced concrete structures	<ul style="list-style-type: none"> Primary demolition of lightweight and standard concrete Primary demolition of heavyweight concrete Wall Elements Secondary demolition 	<input type="radio"/>	<input type="radio"/>	<input type="radio"/>
	Composite steel & concrete structure demolition	<ul style="list-style-type: none"> Primary demolition of lightweight and standard reinforced concrete Primary demolition of heavyweight steel - reinforced concrete Secondary Demolition floors, slabs and beams Separating rebars from pillars and struts Fiber-reinforced concrete Cutting rebars and steel reinforcements 	<input type="radio"/>	<input type="radio"/>	<input type="radio"/>
	Demolition of metallic buildings and structures	<ul style="list-style-type: none"> Demolition of refineries Cutting of Metal and steel structures Cutting steel girders/beams Cutting reinforcements 	<input type="radio"/>	<input type="radio"/>	<input type="radio"/>
	Sorting and loading	<ul style="list-style-type: none"> Sorting Loading Waste handling Site clean-up 	<input type="radio"/>	<input type="radio"/>	<input type="radio"/>
 Earth Moving and Construction	Pavement demolition	<ul style="list-style-type: none"> Asphalt Concrete Composite surfaces 	<input type="radio"/>	<input type="radio"/>	<input type="radio"/>
	Earth moving works	<ul style="list-style-type: none"> Trenching Ground excavation Floor leveling Soil compaction Trench compaction Loading soil or bulk material 	<input type="radio"/>	<input type="radio"/>	<input type="radio"/>
	Foundation works	<ul style="list-style-type: none"> Building foundation excavation Ground leveling 	<input type="radio"/>	<input type="radio"/>	<input type="radio"/>
	Building construction	<ul style="list-style-type: none"> Foundation pile driving Compaction around pillars 	<input type="radio"/>	<input type="radio"/>	<input type="radio"/>



Infrastructures



Metallurgical Industry

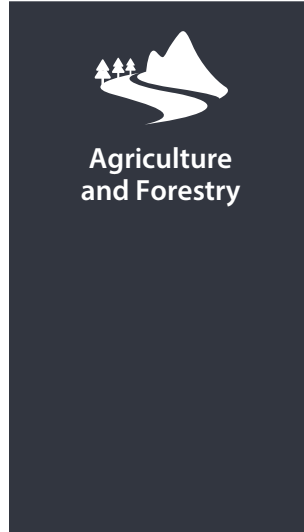

Agriculture and Forestry

		L	M	S
Tunnelling	• Tunnel excavation	○	○	○
	• Roof, face & rib scaling	○	○	○
Underwater application	• Dredging	○	○	○
	• Dock deepening & extension	○	○	○
	• Canal deepening & extension	○	○	○
	• Loading soil or bulk material			
	• Handling rock or breakwaters			
Trenching	• Oil & gas, water & sewage (deep trenching)	○	○	○
	• Trenching		○	○
	• Trench soil compaction		○	○
Road construction	• Pile driving and guard rail driving		○	○
	• Asphalt repair			
	• Maintenance work (driveways, sidewalks and parking lots)			
	• Block paving			
Slag recycling	• Boulder reduction in slag heaps	○	○	
	• Removing blockages at crushing systems	○	○	○
Cleaning & debricking	• Ladles	○	○	○
	• Converter mouths	○	○	○
	• Kilns	○	○	○
Gardening & Landscaping	• Fencing	○	○	○
	• Ground excavation	○	○	○
	• Rock breaking	○	○	○
	• Pit planting	○	○	○
	• Stump splitting	○	○	○
	• Golf course maintenance			
	• Root and stump grinding			
	• Hedgerow clearance and rejuvenation			
• Grinding of logging residues				
Forestry	• Timber log handling			
	• Maintenance of green area, small trees and brush			
	• Creation and upkeep of woodland corridors and firebreaks			
	• Tree clearing			
	• Vegetation clearing			
	• Branch clearing			

L| Large hammers

M| Medium hammers

S| Small hammers



The complete range of Indeco products

Products	Weight/Length	Products	Weight/Length
HP Hydraulic hammers	from 135 to 24400 lbs	IHC R rotating compactors	from 950 to 3350 lbs
IFP fixed pulverisers	from 1650 to 10050 lbs	IMG S-D-H-L-T Multi Grabs	from 630 to 6600 lbs
IRP rotating pulverisers	from 1300 to 9900 lbs	ISS Shears	from 1060 to 24200 lbs
IDC Primary Demolition Crusher	from 1980 to 15850 lbs	IRC rail cutters	from 9240 to 9650 lbs
IMP Multiprocessor	from 3300 to 10800 lbs	IMH Mulching Heads	from 850 to 4250 lbs
IMP Mutiprocessor Car Dismantler	3300 lbs	IBS boom systems	from 11 to 47 ft
IHC fixed compactors	from 450 to 2850 lbs		

*Lengths can be customised on the basis of the customer's needs.

Platinum Warranty

The professional competency which Indeco technicians bring to their job and the easy availability of spare parts in all of its distribution centers enables Indeco to guarantee after-sales service anywhere in the world, that is both rapid and capable of resolving any type of problem. Indeco North America offers an optional Platinum Warranty, which guarantees a hammer owner maximum productivity for a minimal up front purchase. The Platinum Warranty offers virtual "bumper-to-bumper" coverage for a period of twenty-four months.

USA Version



INDECO North America

135 Research Drive
Milford CT, 06460

PH. (203) 713-1030 - F (203) 713-1040

www.indeco-breakers.com

Quality Management
System Certification
UNI EN ISO 9001:2015



Member of



AUTHORISED DEALER